

# Trek electrostatic voltmeters

## Setup, environment, working conditions

Dr. Maciej A. Noras

**Abstract** An analysis of basic sources of errors for electrostatic voltmeter measurements is presented. Stray capacitance and synchronous noise pickup are identified as major contributors to measurement discrepancies.

### 1 Introduction

Every precise instrument requires appropriate conditions of measurements in order to maintain accuracy and reliability of test results. Electrostatic voltmeters (ESVM) are very demanding in that regard. An electric potential and/or charge is detected by the voltmeter by the means of non-contact capacitive coupling between the voltmeter sensor and the surface under test [1–16]. Sensors utilizing this technique are also known as Kelvin probes. A vast majority of ESVMs use vibrating Kelvin probes since this technique allows for fast and accurate measurements. However, signals detected using this method are very minute and easily disturbed. There exist several measurement conditions to be considered so the results are accurate and reliable. The most prominent sources of error for ESVMs are stray capacitances and electromagnetic noise pickup. The electrostatic voltmeter probe can be considered as a distributed capacitance interacting with its surroundings. All fringing fields, vibrating connecting wires, probe holder, etc., will make their contribution to the detected signal. Furthermore, the state of the probe electrodes is usually far from ideal due to oxidation, contamination and the like. These factors can also contribute to inaccuracies in measurements.

### 2 Stray capacitance

Figure 1 presents a simple equivalent circuit for analyzing stray capacitance effects. Such configuration is typical for the Trek probes, where the sensing electrode (no. "1") is sinusoidally vibrated in the direction perpendicular to the tested sur-

face. The surface under test is designated as electrode no. "2". Electrode 2 is at potential  $V_s$  with respect to the earth ground. Electrode "1" is connected to the preamplifier of the electrostatic voltmeter. All stray capacitance is lumped into a single stray electrode "S" with an external bias potential  $V_{st}$ . A nullifying bias voltage  $V_b$ , produced by the ESVM, is applied to electrode "1". It is assumed that the value of resistor  $R$  is very high comparing to the reactance of  $C_{12}$  at the vibration frequency of the sensing electrode.

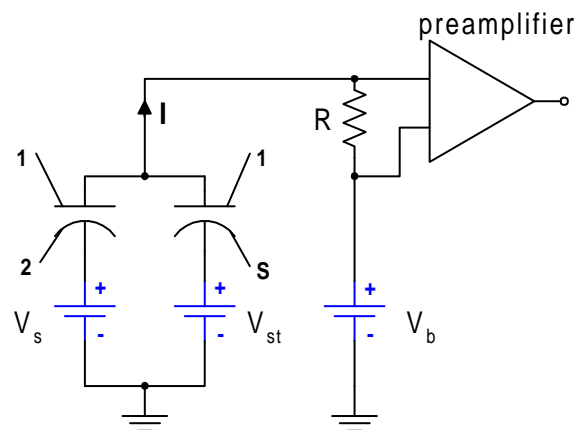

Figure 1: Equivalent circuit for stray capacitance effects.

The charge  $q$  accumulated on the vibrating surface 1 is:

$$q = -C_{12}(V_s - V_b) - C_{1S}(V_{st} - V_b) \quad (1)$$

$C_{12}$  is the capacitance between the probe 1 and the surface 2,

$C_{1S}$  is the lumped stray capacitance between the probe 1 and the surrounding,

## Trek electrostatic voltmeters Setup, environment, working conditions

$V_s$  is the potential difference between the surface 2 and the earth ground,

$V_b$  is the potential difference between the probe 1 and the earth ground (voltage bias),

$V_{st}$  is the difference between the apparent potential detected by the probe 1 and the real value of the potential at the surface 2 - due to the stray capacitance.

Assuming the sinusoidal vibration of the probe 1, equation 1 can be transformed to the formula describing  $V_{st}$  [17]:

$$V_{st} = \frac{C_{1S}^0 m_{1S}}{C_{12}^0 m_{12}} \cdot V_{1S} \quad (2)$$

Where:

$m_{12}$  is the modulation index of the Kelvin probe,

$m_{1S}$  is the modulation index of the stray capacitance,

$C_{1S}^0$  is the average capacitance between the probe and the surrounding,

$C_{12}^0$  is the average capacitance between the probe and the tested surface.

Modulation indexes are defined as the ratio of an amplitude of the probe movement to the average distance of the probe to the tested surface  $d_0$ . Therefore,

$$m_{12} = \frac{a_{probe}}{d_{12}^0}$$

$$m_{1S} = \frac{a_{stray}}{d_{1S}^0},$$

$d_{1S}^0$  is the average distance between the probe and the surrounding,

$d_{12}^0$  is the average distance between the probe and the tested surface.

Note that the modulation index for the stray capacitance is of purely theoretical nature, since it is not possible to determine the average distance between the stray capacitances and the probe. The mathematical model outlined above concludes that, after reformulation of equation 2, the error caused by the stray capacitances increases parabolically with the distance between the probe 1 and the surface under test 2:

$$V_{st} = k \cdot (d_{12}^0)^2 \cdot V_{1S} \quad (3)$$

This prediction suffers from some discrepancies when compared to experimental results [18]. The reason is the fact that the stray capacitances are not all of the parallel-plate type. Nevertheless, an evaluation of the bias voltage  $V_{st}$  over the distance  $d_{12}^0$  is a good way of assessing stray capacitances.

### 2.1 Stray capacitance prevention

The simplest precaution against stray capacitance is keeping the distance  $d_0$  between the probe and the surface under test constant. Then, if the known voltage on the surface under test is kept unchanged as well, it is easy to determine the influence of the stray capacitance as a systematic error at the given value of  $d_0$ . In many practical applications, however, the distance between the probe and the tested surface varies and so does the configuration of the surroundings. In those cases the influence of stray capacitances can be greatly reduced by using proper shielding techniques. The stray capacitance of the shield itself is eliminated by making the probe and the shield of the same material or by applying an auxiliary voltage bias to the shield. There are various styles of shielding techniques available, none of them being 100% effective [15, 19].

Based on the physics of the capacitive coupling to the distant conductive surfaces (distant – as compared to the probe-to-sample spacing) it can be expected that the influence of such stray capacitance would be negligible. This does not neces-

## Trek electrostatic voltmeters

### Setup, environment, working conditions

sarily have to be correct for highly nonuniform distribution of the external electric fields present in the vicinity of the probe. It is important to realize that any source of electromagnetic field placed in proximity of the Kelvin probe can affect the measurement results. Since charged dielectric surfaces produce static electric fields as well, it is a good idea to assure that, for example, the probe holder is made of material that does not retain electric charge (is made of a so called "dissipative" dielectric). The body of the probe and the sensor itself also can accumulate charges due to oxidation, contaminations, etc. Therefore it is beneficial to clean those on regular basis as recommended by the probe manufacturer.

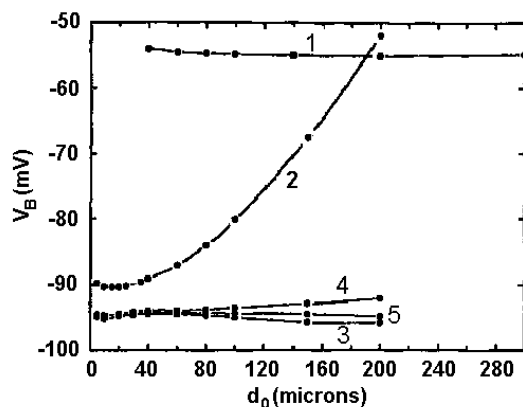

Figure 2: Spacing dependence of the DC bias voltage - influence of stray capacitances [19].

Figure 2 presents the influence of the spacing  $d_0$  between the probe and the tested surface on the bias voltage  $V_B$  that had to be applied to the probe to cancel the effect of stray capacitances [19]. In curve 1 a current amplifier is used and it is connected to the sample instead of the vibrating probe (not very practical for most of applications). Curve 2 presents the bias voltage vs. the distance dependence for the current amplifier connected to the vibrating plate. Increase in the offset voltage values was found to be due to a

spurious microphonic signal injected by the vibrating cables (please see the "Synchronous noise" section of this article). By injecting a similar inverted signal the microphonics could be approximately cancelled, as demonstrated in curves 3, 4 and 5 [19]. Trek electrostatic voltmeters model 520 and 523 utilize current amplifier technique.

### 3 Synchronous noise

The noise sources most difficult to eliminate are those of the frequency equal to the vibration frequency of the probe. They are not removed by the pass-band circuitry. The main source of such noise signal is the residual electrostatic pick-up by the probe (i.e. charge accumulated between the probe and the probe enclosure). Internal and external connecting cables can also contribute to the synchronous noise pickup phenomenon. A particularly difficult type of noise comes from microphonics, which are effects contributed by vibrations of wires and dielectric parts of the probe. The measurement error derived from the microphonics can be distinguished from the stray capacitance error by observing the bias voltage  $V_B$  as a function of the amplitude of vibrations of the probe. Decreased accuracy in the readings of the measured surface potential with increasing amplitude of probe movement indicates that there exists a dominant microphonic pick-up. Had the accuracy increased it would have been because of the prevailing stray capacitance effect.

Most of the Kelvin probe systems are designed in such way so the electric potential of the sensing element of the probe is brought to the value of the potential on the surface under test. The disadvantage of that solution is that at balance the signal to noise ratio reaches a minimum. It has been proven that typical microphonic signals produce much larger spacing dependence error than even most severe nonuniform capacitively coupled surfaces [19]. However, it is difficult to generalize that to all the experimental Kelvin probe setups. Extreme care has to be taken with sensitive pick-up

## Trek electrostatic voltmeters Setup, environment, working conditions

areas such as inputs of the probe preamplifier.

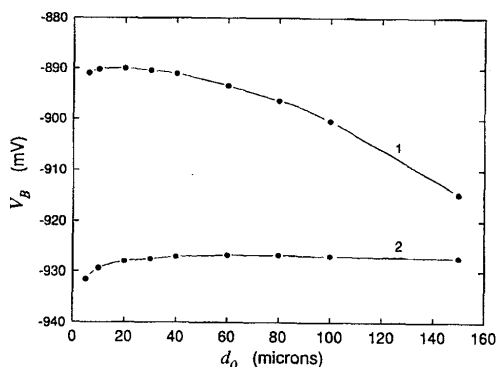

Figure 3: Spacing dependence of the DC bias voltage - influence of microphonics [19].

Figure 3 presents effect of microphonics in the input cable for regular coaxial cable (curve 1) and the same cable with vibration damping and isolation (curve 2).

### 4 Conclusions

In order to optimize the work conditions for electrostatic voltmeters it is important to know all the factors that can possibly affect the accuracy of readings. All capacitive couplings to the probe have their influence. Some of the stray capacitances may be negligible, but others can present a substantial contribution to the measurement error. Stray capacitances influence can be reduced by appropriate shielding. Other sources of error are microphonics and static charges present in the close proximity of the probe and within the construction of the probe. Those can be partially avoided by ensuring that the sensing element of the electrostatic voltmeter is free of contaminants. All wires coming from the probe to the preamplifier are to be secured - Trek probes have this portion of the circuitry built into the probe, so the syn-

chronous pickup by loose cables is minimized. The surface under test itself can also be a contributor to the discrepancies in measurements. As long as there are any localized charges and potentials close to the sensor they will affect the results of testing.

### References

- [1] Lord Kelvin. Contact electricity of metals. *Philos. Mag.*, 46:82–120, 1898.
- [2] W. A. Zisman. *Rev. Sci. Instrum.*, 3:367–368, 1932.
- [3] Foord T. R. Measurement of the distribution of surface electric charge by use of a capacitive probe. *J. Sci. Instrum. (J. Phys. E)*, 2(2):411–413, 1969.
- [4] B. T. Williams and C. R. Hare. Probe for electrostatic voltmeter. U. S. patent no. 3852667, 1974.
- [5] M. Wolff, A. E. Guile, and D. J. Bell. Measurement of localized surface potential differences. *J. Sci. Instrum. (J. Phys. E)*, 2(2):921–924, 1969.
- [6] R. F. Buchheit. Distance compensated electrostatic voltmeter. U. S. patent no. 4106869, 1978.
- [7] J. Bonnet, J. M. Palau, L. Soonckindt, and L. Lassabatere. Sur l'intérêt d'un amplificateur de courant associé au condensateur vibrant dans la méthode de Kelvin. *J. Phys. E: Sci. Instrum.*, 10:212–213, 1977.
- [8] R. E. Vosteen. Electrostatic voltage follower circuit for use as a voltmeter. U. S. patent no. 3525936, 1970.
- [9] R. E. Vosteen. Electrostatic potential and field measurement apparatus having a capacitor detector with feedback to drive the capacitor detector to the potential being measured. U. S. patent no. 3611127, 1971.



## Trek electrostatic voltmeters Setup, environment, working conditions

- [10] R. E. Vosteen. High level non-contacting dynamic voltage follower for voltage measurement of electrostatically charged surfaces. U. S. patent no. 3729675, 1973.
- [11] B. T. Williams. High speed electrostatic voltmeter. U. S. patent no. 4205267, 1980.
- [12] B. T. Williams. Low impedance electrostatic detector. U. S. patent no. 4370616, 1983.
- [13] B. T. Williams. High voltage electrostatic surface potential monitoring system using low voltage A.C. feedback. U. S. patent no. 4797620, 1989.
- [14] F Rossi, G. I. Opat, and A. Cimmino. Modified Kelvin technique for measuring strain-induced contact potentials. *Rev. Sci. Instrum.*, 63(7):3736–3743, 1992.
- [15] S. Danyluk. A UHV guarded Kelvin probe. *J. Phys. E: Sci. Instrum.*, 5:478–480, 1972.
- [16] D. M. Zacher. Feedback-based field meter eliminates need for HV source. *EE Eval. Eng.*, pages S43–S45, November 1995.
- [17] I. D. Baikie and E. Venderbosch. Analysis of stray capacitance in the Kelvin method. *Rev. Sci. Instrum.*, 62(3):725–734, March 1991.
- [18] R. J. D’Arcy and N. A. Surplice. The effects of stray capacitance on the Kelvin method for measuring contact potential difference. *J. Phys. D: Appl. Phys.*, 3:482–488, 1970.
- [19] F. Rossi. Contact potential measurement: Spacing dependent errors. *Rev. Sci. Instrum.*, 63(9):4174–4181, September 1992.

